

# HDD Mud Pump PSE 55-150

Compact high-capacity pump for drilling fluids operating at pressures up to 350 bar.

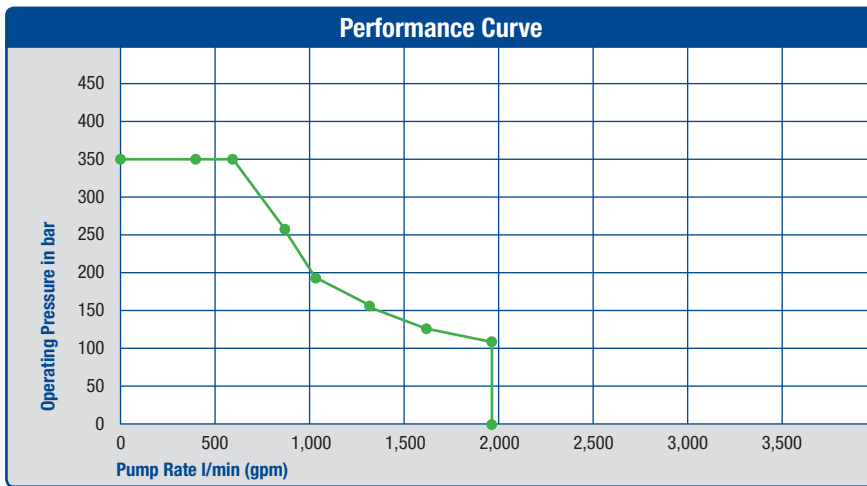
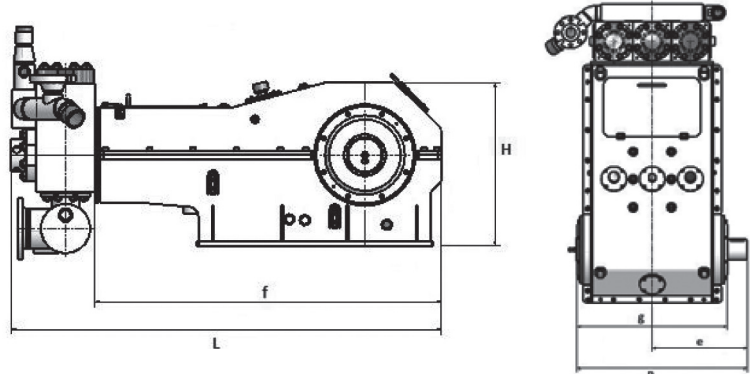
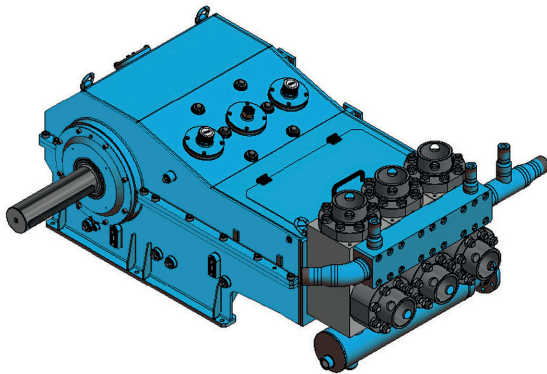

**Dimensions**

|                           |          |
|---------------------------|----------|
| L Total Length            | 2,001 mm |
| F Length only power end   | 1,550 mm |
| H Total Height            | 934 mm   |
| B Total Width             | 1,195 mm |
| g Width excluding journal | 916 mm   |
| e Width from center line  | 679 mm   |

| Piston-Ø              | Inch      | 2,5                             | 3           | 3,5         | 4           | 4,5         | 5           | 5,5         |
|-----------------------|-----------|---------------------------------|-------------|-------------|-------------|-------------|-------------|-------------|
|                       | mm        | 63.5                            | 76.2        | 88.9        | 101.6       | 114.3       | 127         | 139.7       |
| Operat. Pressure      | bar (psi) | 350 (5,076)                     | 350 (5,076) | 255 (3,699) | 195 (2,828) | 155 (2,248) | 125 (1,813) | 105 (1,523) |
| <b>Revolutions</b>    |           | <b>Pumping Rate l/min (gpm)</b> |             |             |             |             |             |             |
| 285 min <sup>-1</sup> |           | 406 (107)                       | 585 (155)   | 796 (210)   | 1,040 (275) | 1,316 (348) | 1,625 (429) | 1,966 (519) |
| 250 min <sup>-1</sup> |           | 356 (94)                        | 513 (136)   | 698 (184)   | 912 (241)   | 1,154 (305) | 1,425 (376) | 1,724 (455) |
| 200 min <sup>-1</sup> |           | 285 (75.3)                      | 410 (108)   | 559 (148)   | 730 (193)   | 923 (244)   | 1,140 (301) | 1,380 (365) |
| 150 min <sup>-1</sup> |           | 214 (56.5)                      | 308 (81.4)  | 419 (111)   | 547 (145)   | 693 (183)   | 855 (226)   | 1,035 (273) |
| 100 min <sup>-1</sup> |           | 143 (37.8)                      | 205 (54.2)  | 279 (73.7)  | 364 (96.2)  | 462 (122)   | 570 (151)   | 690 (182)   |
| 50 min <sup>-1</sup>  |           | 71 (18.8)                       | 103 (27.2)  | 140 (37)    | 182 (48.1)  | 231 (61)    | 285 (75.3)  | 345 (91.1)  |

**Data Performance**

|                      |  |
|----------------------|--|
| Weight               | approx. 3,350 kg   |
| Pumping Rate         | up to 1,966 l/min  |
| Drive Power          | up to 400 kW   |
| Fluids               | Drilling Suspension, Bentonite Mixture                                     |
| Fluid Temperature    | up to 90 °C  |
| Piston Force Max.    | 160,000 N  |
| Stroke               | 150 mm   |
| Average Piston Speed | 285 min-1: 1.43 m/sec.<br>250 min-1: 1.25 m/sec.<br>200 min-1: 1.00 m/sec. |