

HDD Mud Pump PSE 55-150 C

Compact high-capacity pump for drilling fluids operating at pressures up to 150 bar.

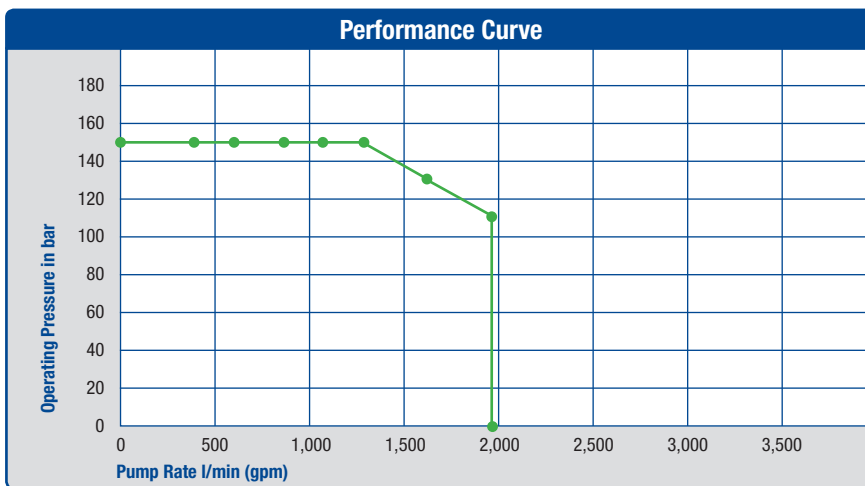
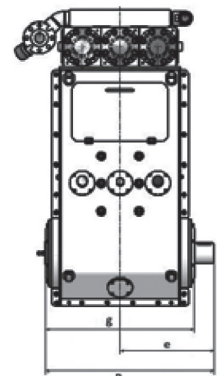
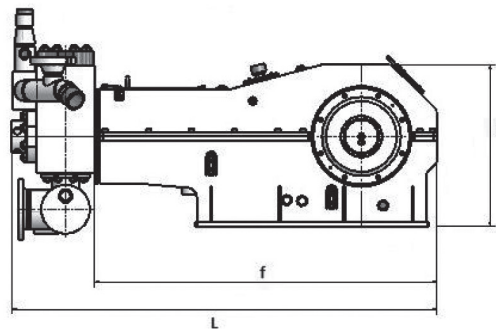
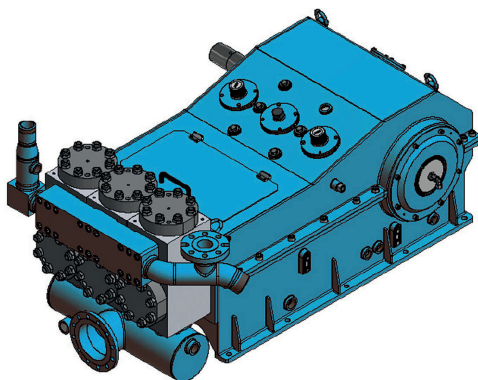

Dimensions

L Total Length	2,001 mm
f Length only power end	1,550 mm
H Total Height	972 mm
B Total Width	1,374 mm
g Width excluding journal	990 mm
e Width from center line	679 mm

Piston-Ø	Inch	2,5	3	3,5	4	4,5	5	5,5
	mm	63.5	76.2	88.9	101.6	114.3	127	139.7
Operat. Pressure	bar (psi)	150 (2,176)	150 (2,176)	150 (2,176)	150 (2,176)	150 (2,176)	125 (1,813)	105 (1,523)
Revolutions		Pumping Rate l/min (gpm)						
285 min ⁻¹		406 (107)	585 (155)	796 (210)	1,040 (275)	1,316 (348)	1,625 (429)	1,966 (519)
250 min ⁻¹		356 (94)	513 (136)	698 (184)	612 (162)	1,154 (305)	1,425 (376)	1,724 (455)
200 min ⁻¹		285 (75.3)	410 (108)	559 (148)	730 (193)	923 (244)	1,140 (301)	1,380 (365)
150 min ⁻¹		214 (56.5)	308 (81.4)	419 (111)	547 (145)	693 (183)	855 (226)	1,035 (273)
100 min ⁻¹		143 (37.8)	205 (54.2)	279 (73.7)	365 (96.4)	462 (122)	570 (151)	690 (182)
50 min ⁻¹		71 (18.8)	103 (27.2)	140 (37)	182 (48.1)	231 (61)	285 (75.3)	345 (91.1)

Data Performance

Weight	approx. 2,850 kg
Pumping Rate	up to 1,966 l/min
Drive Power	up to 400 kW
Fluids	Drilling Suspension, Bentonite Mixture
Fluid Temperature	up to 90 °C
Piston Force Max.	160,000 N
Stroke	150 mm
Average Piston Speed	285 min ⁻¹ : 1.43 m/sec. 250 min ⁻¹ : 1.25 m/sec. 200 min ⁻¹ : 1.00 m/sec.