

# HDD Mud Pump PSE 60-180 C

Compact high-capacity pump for drilling fluids operating at pressures up to 150 bar.

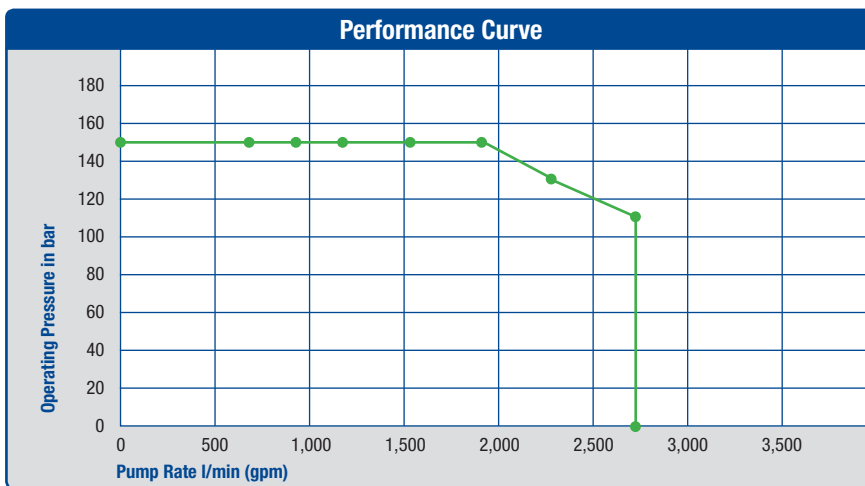
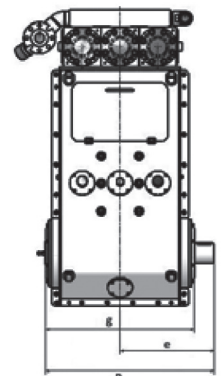
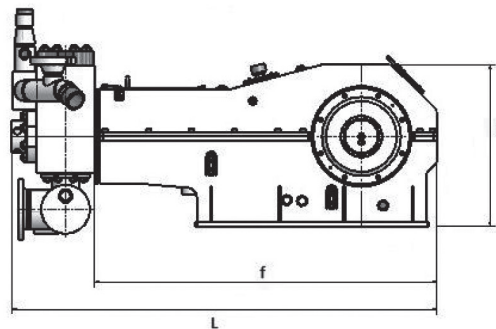
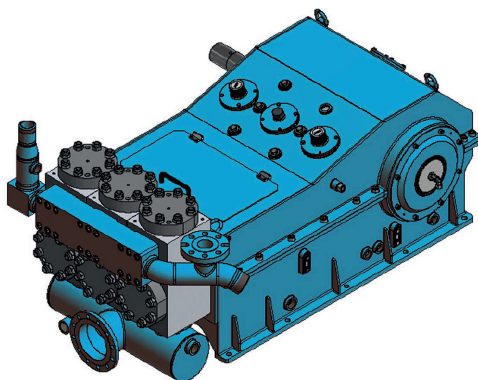

**Dimensions**

L Total Length	2,280 mm
F Length only power end	1,830 mm
H Total Height	900 mm
B Total Width	1,250 mm
g Width excluding journal	1,000 mm
e Width from center line	750 mm

Piston-Ø	Inch	3	3.5	4	4.5	5	5.5	6
	mm	76.2	88.9	101.6	114.3	127	139.7	152.4
Operat. Pressure	bar (psi)	150 (2,176)	150 (2,176)	150 (2,176)	150 (2,176)	150 (2,176)	130 (1,886)	110 (1,595)
<b>Revolutions</b>		<b>Pumping Rate l/min (gpm)</b>						
275 min <sup>-1</sup>		677 (179)	922 (244)	1,204 (318)	1,524 (403)	1,881 (497)	2,276 (601)	2,709 (716)
250 min <sup>-1</sup>		616 (163)	838 (221)	1,094 (289)	1,385 (366)	1,710 (452)	2,069 (547)	2,463 (651)
200 min <sup>-1</sup>		493 (130)	670 (177)	876 (231)	1,108 (293)	1,368 (361)	1,655 (437)	1,970 (520)
150 min <sup>-1</sup>		369 (97.5)	503 (133)	657 (174)	831 (220)	1,026 (271)	1,242 (328)	1,478 (390)
100 min <sup>-1</sup>		246 (62)	335 (88.5)	438 (116)	554 (146)	684 (181)	828 (219)	985 (260)
50 min <sup>-1</sup>		123 (32.5)	168 (44.4)	219 (57.9)	277 (73.2)	342 (90.3)	414 (109)	493 (130)

**Data Performance**

Weight	approx. 4,250 kg
Pumping Rate	up to 2,709 l/min
Drive Power	up to 575 kW
Fluids	Drilling Suspension, Bentonite Mixture
Fluid Temperature	up to 90 °C
Piston Force Max.	200,000 N
Stroke	180 mm
Average Piston Speed	275 min-1: 1.65 m/sec. 250 min-1: 1.50 m/sec. 200 min-1: 1.20 m/sec.