

Slurry Pump PSE SP 106

Compact high-capacity pump for drilling fluids operating at pressures up to 500 bar.

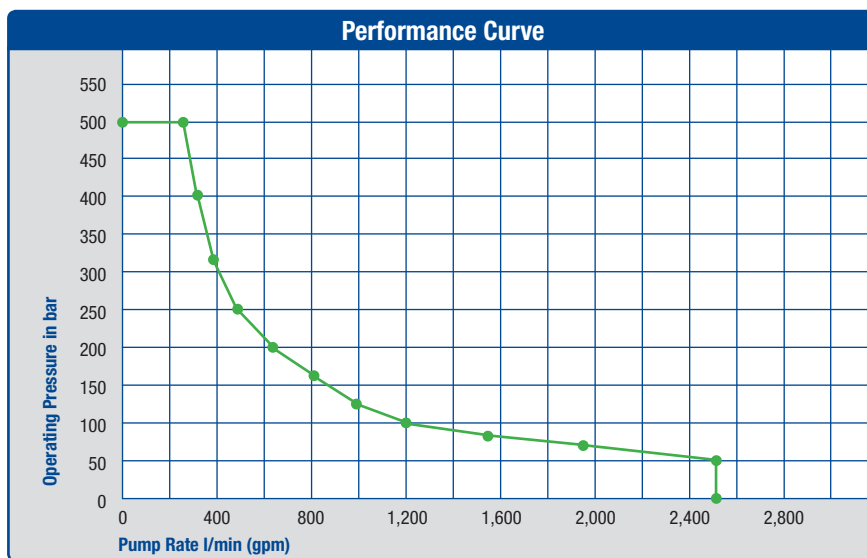
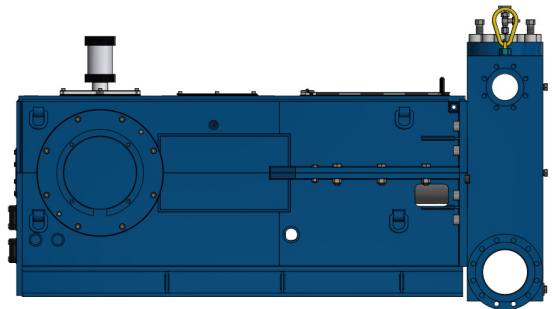
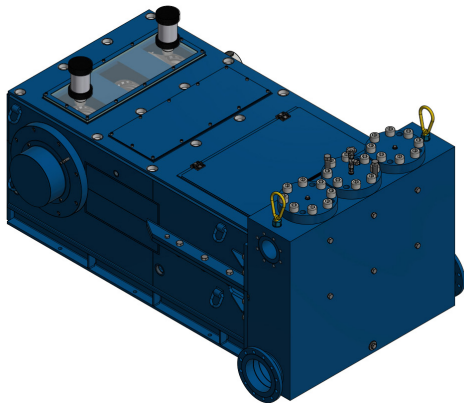

Dimensions

L Total Length	2,460 mm
f Length only power end	2,072 mm
H Total Height	1,431 mm
B Total Width	1,632 mm
g Width excluding journal	1,300 mm
e Width from center line	984 mm

Piston-Ø	mm	160	140	125	110	100	90	80	70	63	56	50
Operat. Pressure	bar	50	63	80	100	125	160	200	250	315	400	500
Revolutions		Pumping Rate l/min (gpm)										
234 min ⁻¹		2,540	1,945	1,550	1,200	992	804	635	486	394	311	248

Data Performance

Weight	approx. 8,500 kg
Pumping Rate	up to 2,540 l/min
Drive Power	up to 500 kW
Fluids	Slurry
Fluid Temperature	up to 300 °C
Piston Force Max.	169,600 N
Stroke	180 mm