

# Slurry Pump PSE SP 125

Compact high-capacity pump for drilling fluids operating at pressures up to 500 bar.

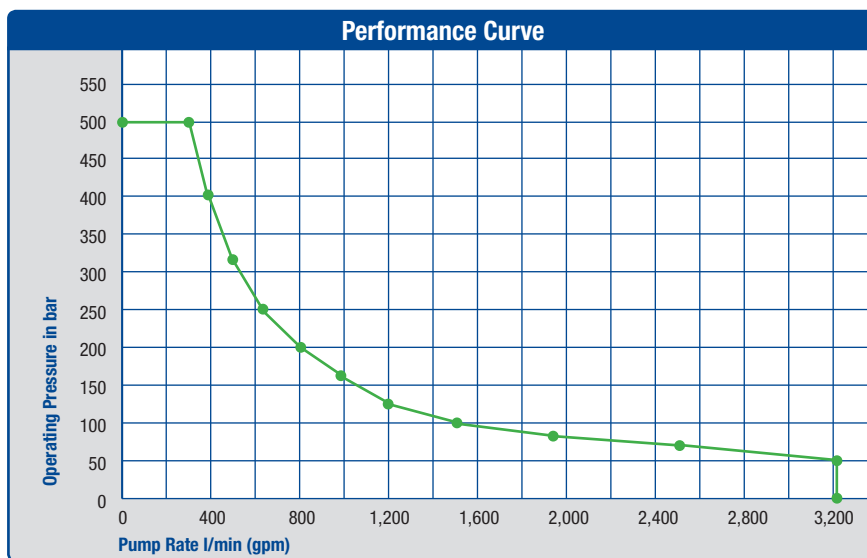
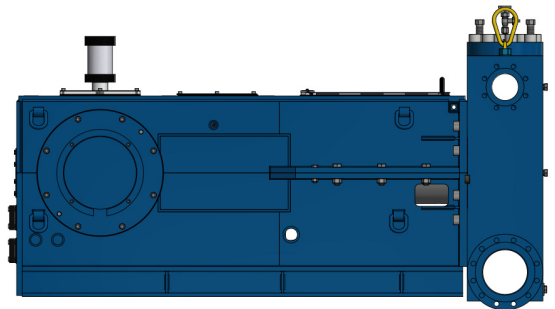
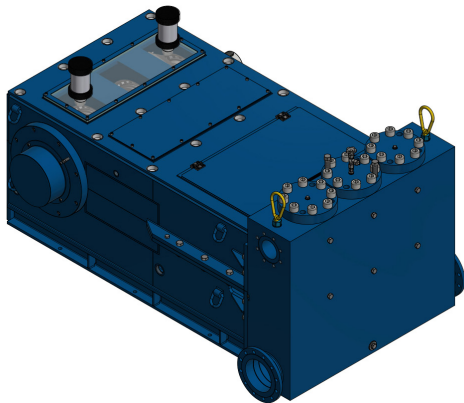

**Dimensions**

L Total Length	2,838 mm
f Length only power end	2,391 mm
H Total Height	1,651 mm
B Total Width	1,882 mm
g Width excluding journal	1,500 mm
e Width from center line	1,135 mm

Piston-Ø	mm	180	160	140	125	110	100	90	80	70	63	56
Operat. Pressure	bar	50	63	80	100	125	160	200	250	315	400	500
<b>Revolutions</b>		<b>Pumping Rate l/min (gpm)</b>										
234 min <sup>-1</sup>		3,215	2,540	1,945	1,550	1,200	992	804	635	486	394	311

**Data Performance**

Weight	approx. 11,000 kg
Pumping Rate	up to 3,215 l/min
Drive Power	up to 500 kW
Fluids	Slurry
Fluid Temperature	up to 300 °C
Piston Force Max.	200,000 N
Stroke	180 mm
Average Piston Speed	234 min <sup>-1</sup> : 1.04 m/sec.