

Slurry Pump PSE SP 57

Compact high-capacity pump for drilling fluids operating at pressures up to 500 bar.

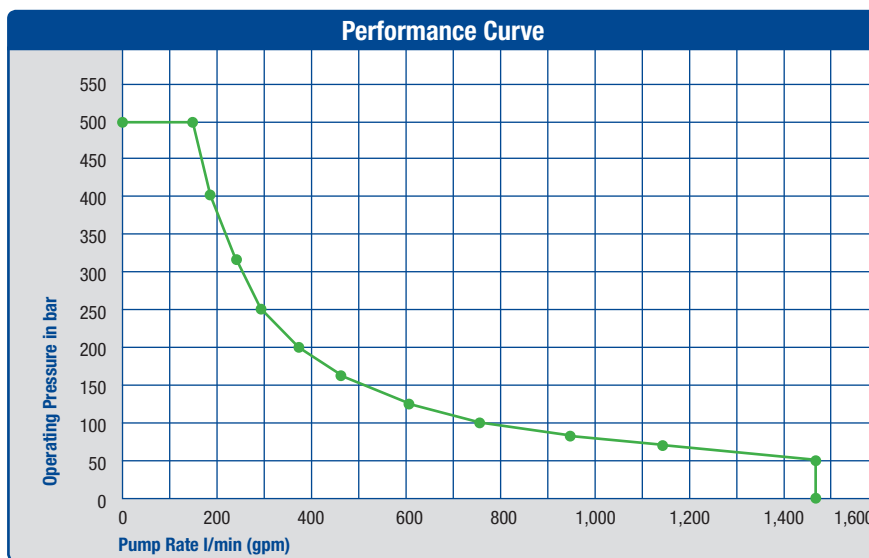
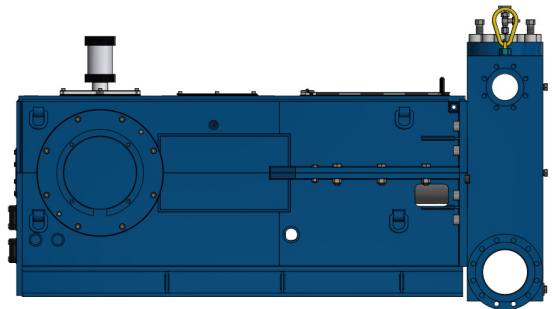
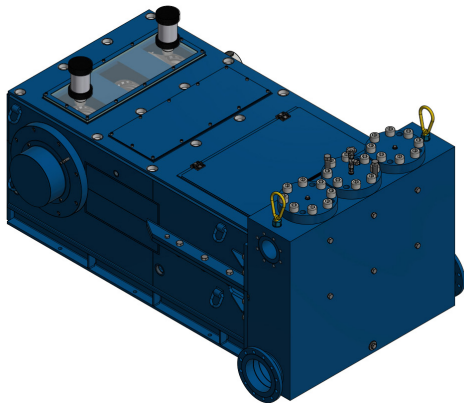

Dimensions

| | |
|---------------------------|----------|
| L Total Length | 1,798 mm |
| f Length only power end | 1,514 mm |
| H Total Height | 1,046 mm |
| B Total Width | 1,193 mm |
| g Width excluding journal | 1,037 mm |
| e Width from center line | 784 mm |

| Piston-Ø | mm | 125 | 110 | 100 | 90 | 80 | 70 | 63 | 56 | 50 | 45 | 40 |
|-----------------------|-----|---------------------------------|-------|-----|-----|-----|-----|-----|-----|-----|-----|-----|
| Operat. Pressure | bar | 50 | 63 | 80 | 100 | 125 | 160 | 200 | 250 | 315 | 400 | 500 |
| Revolutions | | Pumping Rate l/min (gpm) | | | | | | | | | | |
| 286 min ⁻¹ | | 1,474 | 1,141 | 943 | 764 | 604 | 462 | 374 | 296 | 236 | 191 | 151 |

Data Performance

| | |
|----------------------|-------------------------------------|
| Weight | approx. 4,500 kg |
| Pumping Rate | up to 1,474 l/min |
| Drive Power | up to 500 kW |
| Fluids | Slurry |
| Fluid Temperature | up to 300 °C |
| Piston Force Max. | 91,200 N |
| Stroke | 140 mm |
| Average Piston Speed | 286 min ⁻¹ : 1.33 m/sec. |